

FP TROFFER-STRIP SENSOR

Models: 87-103



INSTALLATION AND SAFETY INSTRUCTIONS

IMPORTANT: Read before installing fixture. Retain for future reference.

WARNING: Risk of Fire or Electric Shock

Only authorized, qualified personnel should install this fixture and should follow the owner's manual. Any improper installation might cause failure, electric shock, fire or other injury, damage or hazard.

INSTALLATION:

STEP 1: Turn OFF power at circuit breaker before installing the unit.

STEP 2: The device requires an oval die cut in the sheet metal as shown.

STEP 3: Make sure the luminaire can be 0-10V dim to OFF, and the driver has AUX output.

STEP 4: Screw the sensor into the receptacle and make sure the connections are tight. Ensure the rubber gasket touches the outside surface of the fixture.

STEP 5: Attach the lens to the sensor and turn the lens module clockwise to ensure it locks in place.

STEP 6: Refer to the Wiring Diagram for connections. See page 2.

STEP 7: Turn power back ON at the circuit breaker.

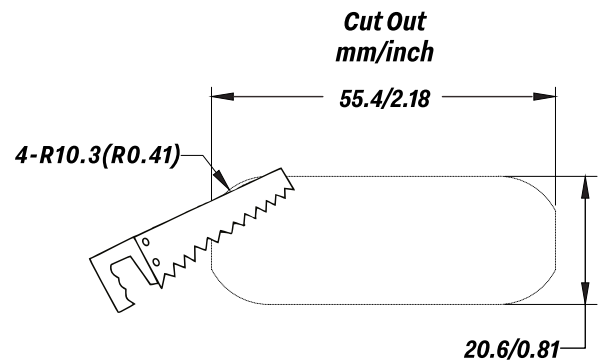
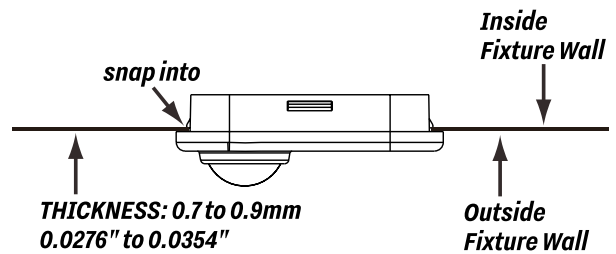

Scan below QR code for downloading the APP.



How to Control Lights with a Phone?

Scan to download APP instruction.



NOTE: This sensor is Bluetooth® compatible. The Bluetooth® word mark and logos are registered trademarks owned by Bluetooth SIG, Inc. and any use of such marks by SATCO Products, Inc., is under license. Other trademarks and trade names are those of their respective owners.

WARRANTY: This product is guaranteed for a 5-year warranty. Any quality issue in normal use within the warranty period, will be repaired or replaced according to the situation and under the condition specifications can be provided. Visit www.Satco.com for full warranty details and dimmer compatibility information.

WIRING DIAGRAM

