

ZONE CONTROLLER

Models: 87-202



INSTALLATION AND SAFETY INSTRUCTIONS

IMPORTANT: Read before installing fixture. Retain for future reference.



WARNING: Risk of Fire or Electric Shock

Only authorized, qualified personnel should install this fixture and should follow the owner's manual. Any improper installation might cause failure, electric shock, fire or other injury, damage or hazard.

INSTALLATION:

STEP 1: Turn OFF power at circuit breaker before installing the unit.

STEP 2: Drill 1/2" KO in the sheet metal for 87-202 installation, make sure the 87-202 is well fixed in the luminaire.

STEP 3: Screw the sensor into the receptacle and make sure the connection is tight. Ensure the rubber gasket touches the outside surface of the fixture.

STEP 4: Refer to the Wiring Diagram for connections. See page 2.

STEP 5: Turn power back ON at the circuit breaker.

RESET: Press and hold the Reset button for three seconds until the blue indicator light starts flashing continuously, then release it.

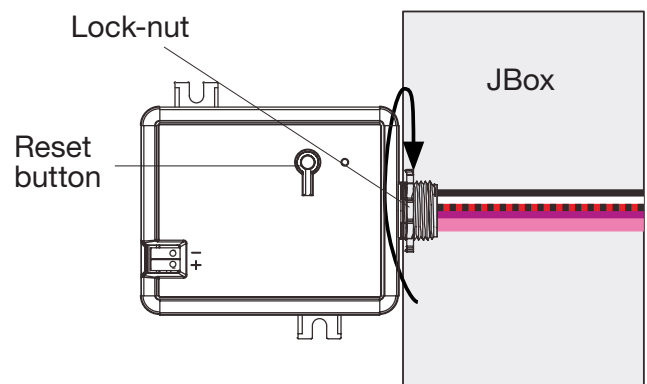

Scan below QR code for downloading the APP.



How to Control Lights with a Phone?

Scan to download APP instruction.



NOTE: This sensor is Bluetooth® compatible. The Bluetooth® word mark and logos are registered trademarks owned by Bluetooth SIG, Inc. and any use of such marks by SATCO Products, Inc., is under license. Other trademarks and trade names are those of their respective owners.

WARRANTY: This product is guaranteed for a 5-year warranty. Any quality issue in normal use within the warranty period, will be repaired or replaced according to the situation and under the condition specifications can be provided. Visit www.Satco.com for full warranty details and dimmer compatibility information.

WIRING DIAGRAM

