

3 BUTTON WIRELESS KEYPAD

Models: 87-501



INSTALLATION AND SAFETY INSTRUCTIONS

IMPORTANT: Read before installing fixture. Retain for future reference.



WARNING: Risk of Fire or Electric Shock

Only authorized, qualified personnel should install this fixture and should follow the owner's manual. Any improper installation might cause failure, electric shock, fire or other injury, damage or hazard.

Turn OFF power at circuit breaker before installing the unit.

INSTRUCTIONS:

STEP 1: Install 1pc CR2032 battery.

STEP 2: Press button "ON/OFF" and "^" together over 2 seconds to enter pairing mode and achieve reset function. This switch can be scanned in next 30 seconds.

STEP 3: In the App "Switch" page, click to add the switch.

STEP 4: Select the light/light group to be controlled by this switch.

IMPORTANT: Battery model #CR2032 can be used for 5 years based on the usage of twice a day.

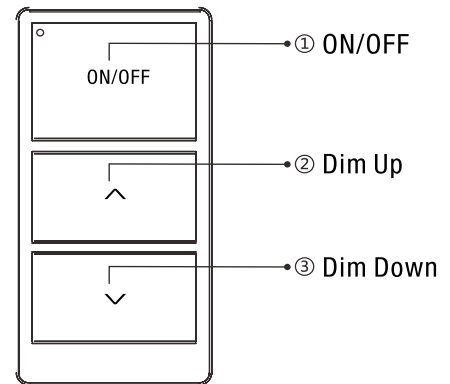

BATTERY INSTALLATION:

STEP 1: Pry up the cover of Remote Controller with a flat screw driver.

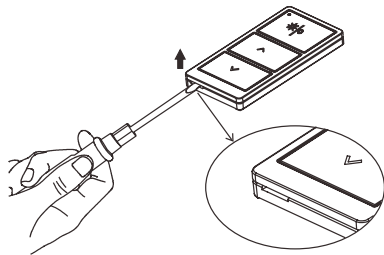

STEP 2: Replace the battery with new one.

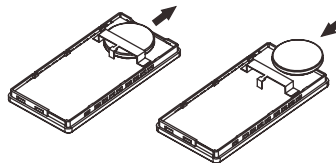

STEP 3: Attach the cover.

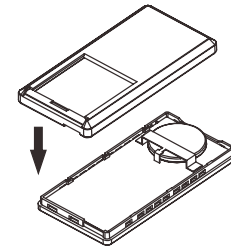

BATTERY RECYCLE/DISPOSAL: Remove and immediately recycle or dispose of used batteries according to local regulations and keep away from children. Do NOT dispose of batteries in household trash or incinerate.

- Even used batteries may cause severe injury or death.
- Call a local poison control center for treatment information.
- Identification of compatible battery type
- Nominal battery voltage.
- Non-rechargeable batteries are not to be recharged.
- Do not force discharge, recharge, disassemble, heat above (manufacturer's specified temperature rating) or incinerate. Doing so may result in injury due to venting, leakage or explosion resulting in chemical burns.

⚠ WARNING

- **INGESTION HAZARD:** This product contains a button cell or coin battery
- **DEATH** or serious injury can occur if ingested.
- A swallowed button cell or coin battery can cause **Internal Chemical Burns** in as little as **2 hours**.
- **KEEP** new and used batteries **OUT OF REACH** of **CHILDREN**
- **Seek immediate medical attention** if a battery is suspected to be swallowed or inserted inside any part of the body.



WALL SURFACE INSTALLATION:

STEP 1: Remove the cover plate carefully with scissors.

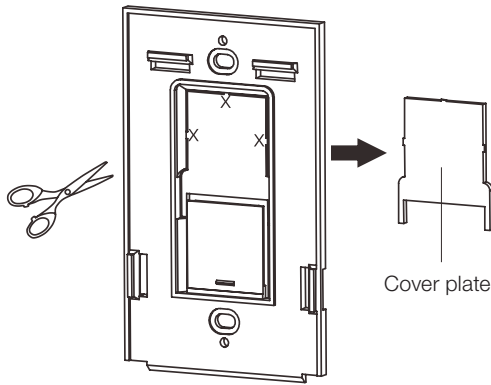

STEP 2: Mark a position you want to install.

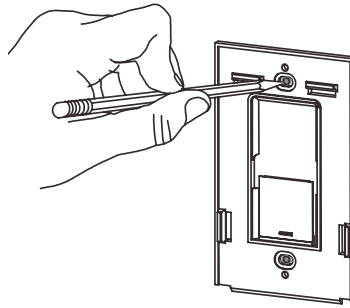

STEP 3: Drill two holes with power drill.

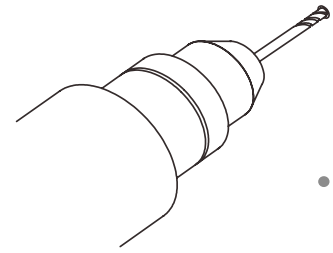

STEP 4: Attach the Bracket with supplied self-tapping screws.

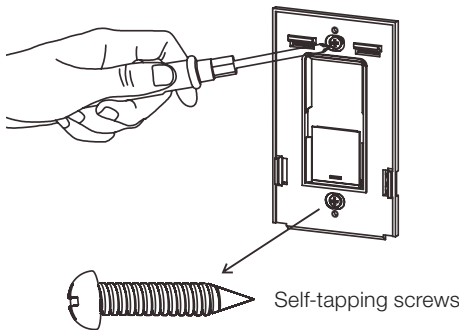

STEP 5: Slide Remote Controller into the bracket.

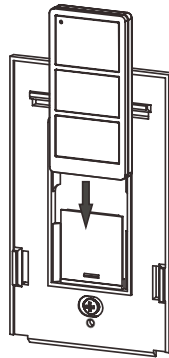

STEP 6: Attach the wallplate.

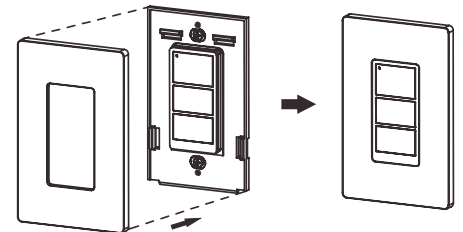

Scan below QR code for downloading the APP.



How to Control Lights with a Phone?

Scan to download APP instruction.



NOTE: This sensor is Bluetooth® compatible. The Bluetooth® word mark and logos are registered trademarks owned by Bluetooth SIG, Inc. and any use of such marks by SATCO Products, Inc., is under license. Other trademarks and trade names are those of their respective owners.

WARRANTY: This product is guaranteed for a 5-year warranty. Any quality issue in normal use within the warranty period, will be repaired or replaced according to the situation and under the condition specifications can be provided. Visit www.Satco.com for full warranty details and dimmer compatibility information.